



# PPD-230

## Peristaltic Pump Dispenser

### Operating Manual

[info@fisnar.com](mailto:info@fisnar.com)

[www.fisnar.com](http://www.fisnar.com)

## Table of Contents

<b>Machine Overview</b>	<b>3</b>
<b>Product Safety Statements</b>	<b>4</b>
<b>Specifications</b>	<b>6</b>
<b>Accessories</b>	<b>6</b>
<b>External Controls</b>	<b>7</b>
• <b>Front</b>	<b>8</b>
• <b>Back</b>	<b>11</b>
• <b>Control Buttons</b>	<b>12</b>
<b>Machine Setup</b>	<b>14</b>
<b>Dispense Setup</b>	<b>15</b>
<b>Dispense Modes</b>	<b>18</b>
• <b>Manual Mode</b>	<b>18</b>
• <b>Timed Mode</b>	<b>21</b>
• <b>Cycle Mode</b>	<b>27</b>
<b>Function Menu</b>	<b>30</b>
• <b>Auto Cycle Stop</b>	<b>32</b>
• <b>Retract Speed</b>	<b>33</b>
• <b>Manual Actuation Switch Type</b>	<b>34</b>
• <b>Motor Current Overload Alarm</b>	<b>35</b>
• <b>Lock Screen</b>	<b>36</b>
• <b>Program Version</b>	<b>37</b>
• <b>Dispense Count</b>	<b>38</b>
• <b>Total Machine Cycles</b>	<b>39</b>
• <b>Total Dispense Time</b>	<b>40</b>
• <b>Language</b>	<b>41</b>
<b>External Machine Actuation</b>	<b>42</b>
<b>I/O Specification</b>	<b>43</b>
• <b>Schematic</b>	<b>43</b>
• <b>Output Signal Logic</b>	<b>44</b>
• <b>Input Signal Logic</b>	<b>45</b>
• <b>Output Signal Definition</b>	<b>46</b>
• <b>Input Signal Definition</b>	<b>47</b>
<b>Spare Part List</b>	<b>48</b>
<b>Technical Drawing</b>	<b>49</b>
• <b>PPD-230</b>	<b>49</b>
• <b>Dispense Pen Assembly</b>	<b>49</b>
• <b>Dispense Pen Holder &amp; Bottle Stand</b>	<b>50</b>
<b>Appendix</b>	<b>51</b>
• <b>Appendix 1 – Tubing Installation (Pen Body)</b>	<b>51</b>
• <b>Appendix 2 – Tubing Installation (Pump Head)</b>	<b>53</b>
• <b>Appendix 3 – Tubing Installation (Reservoir)</b>	<b>54</b>

## OVERVIEW



**Model PPD-230 Peristaltic Pump Dispenser**

Peristaltic pump dispensers transfer low-viscosity liquids by pressure displacement applied to a turning rotor against a tube-carrying fluid.

The PPD-230 offers excellent features for air-free positive displacement dispensing of materials, such as cyanoacrylates, anaerobics, solvents, acids and other low viscosity fluids.

Dispense outputs can be timed from 0.01 to 999.9 seconds with flow speeds from 2.9 to 20.3 ml/min using high performance silicone or thermo plastic elastomer (TPE) tubing. The bidirectional control of the pump allows the fluid to be retracted backwards inside the tubing to prevent dripping.

### Three Operation Modes

A manual mode – The dispense operation is manually controlled by a switch on the dispense pen.

A timed mode – Dispenses at a pre-set time for controlled, repeatable shot sizes.

A cycle mode – Continually dispenses at a pre-set time and at a pre-set interval.

One programmable memory slot.

Air-free dispensing

Digital timer and speed control for accurate and repeatable dispense results

Adjustable forward & reverse pump speed control

Programmable delay time before reverse direction to control suck-back of fluid flow

Operator lockout function to protect programs from being modified

Output signal to indicate end of cycle

Large segment digital LED display







Dispense cycle counter for tracking completed dispense cycles

7 channel I/O circuit for external control and robot integration



Compact & durable aluminum housing designed for industrial work environments

## SAFETY

### General Precautions

- |                                                                                   |                                                                                                                                                       |
|-----------------------------------------------------------------------------------|-------------------------------------------------------------------------------------------------------------------------------------------------------|
|  | <i>Do not operate the machine in excess of its maximum ratings / settings.</i>                                                                        |
|  | <i>Ensure the area where the equipment is being used is well ventilated, to reduce exposure to vapors of fluid being dispensed.</i>                   |
|  | <i>Wear protective safety equipment as specified in the material safety data sheet of the fluid being dispensed.</i>                                  |
|  | <i>The fluid being dispensed may be toxic and / or hazardous. Refer to the Material Safety Data Sheet for proper handling and safety precautions.</i> |
|  | <i>Do not smoke or use near an open flame when flammable materials are being dispensed.</i>                                                           |
|  | <i>Do not expose the machine directly to sunlight.</i>                                                                                                |
|  | <i>Avoid cleaning the machine with aggressive solvents – neutral detergents are preferred.</i>                                                        |





### PPD-230 Malfunction

- |                                                                                     |                                                                                                                                                                                                              |
|-------------------------------------------------------------------------------------|--------------------------------------------------------------------------------------------------------------------------------------------------------------------------------------------------------------|
|  | <i>If the machine malfunctions, shut down the machine immediately. This can be done by either pushing the power switch at the back of the machine into the off position or disconnecting the power cord.</i> |
|  | <i>Remove the fluid tubing from the pump head.</i>                                                                                                                                                           |
|  | <i>Identify the cause of machine malfunction and fix accordingly before switching back on.</i>                                                                                                               |

## SAFETY





### Inappropriate Use

If the machine is used in a way other than described in this manual, it may cause damage to self or property.

-  ***Do not use any components with the machine other than Fisnar authorized components.***
-  ***Do not use incompatible materials.***
-  ***Do not make any modifications to the machine. All repairs are to be done using Fisnar specified spare parts.***
-  ***Do not operate the machine in excess of its maximum ratings / settings.***





### Fire Prevention

Refer to the following instructions to avoid any fire or explosion.

-  ***Assess your surroundings and the location of the nearest fire extinguisher and Emergency Exit.***
-  ***Do not smoke or use near an open flame when flammable materials are being dispensed.***
-  ***Immediately disconnect power if any sparking or smoke appears.***
-  ***Do not expose the machine directly to sunlight.***

### Maintenance

The PPD-230 is generally a maintenance free machine. However, to ensure smooth operation please follow the below instructions.

-  ***Only use non-woven cleaners on the machine.***
-  ***Inspect fluid tubing daily, for signs of fatigue and replace as necessary.***
-  ***Inspect the pump head daily, to ensure it is free of foreign contaminants.***
-  ***Periodically check electrical connections are secure.***

## SPECIFICATIONS

Dimensions (W x D x H):	7.56" x 6.22" x 3.00" (192 x 158 x 76 mm)
Weight:	1.5 lbs (0.68 kg)
Input AC to Power Supply:	100 – 240 VAC, 50 / 60 Hz
Output DC from Power Supply:	24 VDC – 1 Amp
Relative Humidity:	20 – 90% (No Condensation)
Operating Temperature:	50 – 104°F (10 – 40°C)
Timer:	0.01 – 999.9 seconds
Flow Speed:	2.9 – 20.3 ml/min
Pump Speed:	Up to 107 rpm
Max Fluid Viscosity	Up to 5,000 Cps
Standards:	CE Approved, EMC Compliant, RoHS Compliant

## ACCESSORIES

Item	Description	Quantity
5601911	Power Adaptor (Input: 100 – 240 VAC / Output: 24 VDC)	1
5602009	Dispense Pen Assembly	1
5602010	Luer Lock Dispense Nozzle – 2mm Hose Barb (White)	1
5602011	Luer Lock Dispense Nozzle – 3mm Hose Barb (Black)	1
5602013	Innovaprene™ 1.0mm I.D. x 3.0mm O.D. Tubing - Tan	1
5602015	Innovaprene™ 2.0mm I.D. x 4.0mm O.D. Tubing - Tan	1
5602012	Innovasil™ 1.0mm I.D. x 3.0mm O.D. Tubing - Natural	1
5602014	Innovasil™ 2.0mm I.D. x 4.0mm O.D. Tubing - Natural	1
5602016	Dispense Pen Holder & Bottle Stand	1
5601971	Drip Bottle & Cap	2
5601970	Purge Tray	10
EARB424	4oz Round Bottle - Natural	1
EARB424-BK	4oz Round Bottle - Black	1
EARC24	Ribbed Cap	2
5602017	Snap Top Cap – 0.25" Orifice	2
2146T13	15 Pin D-Sub Connector Plug	1

## EXTERNAL CONTROLS

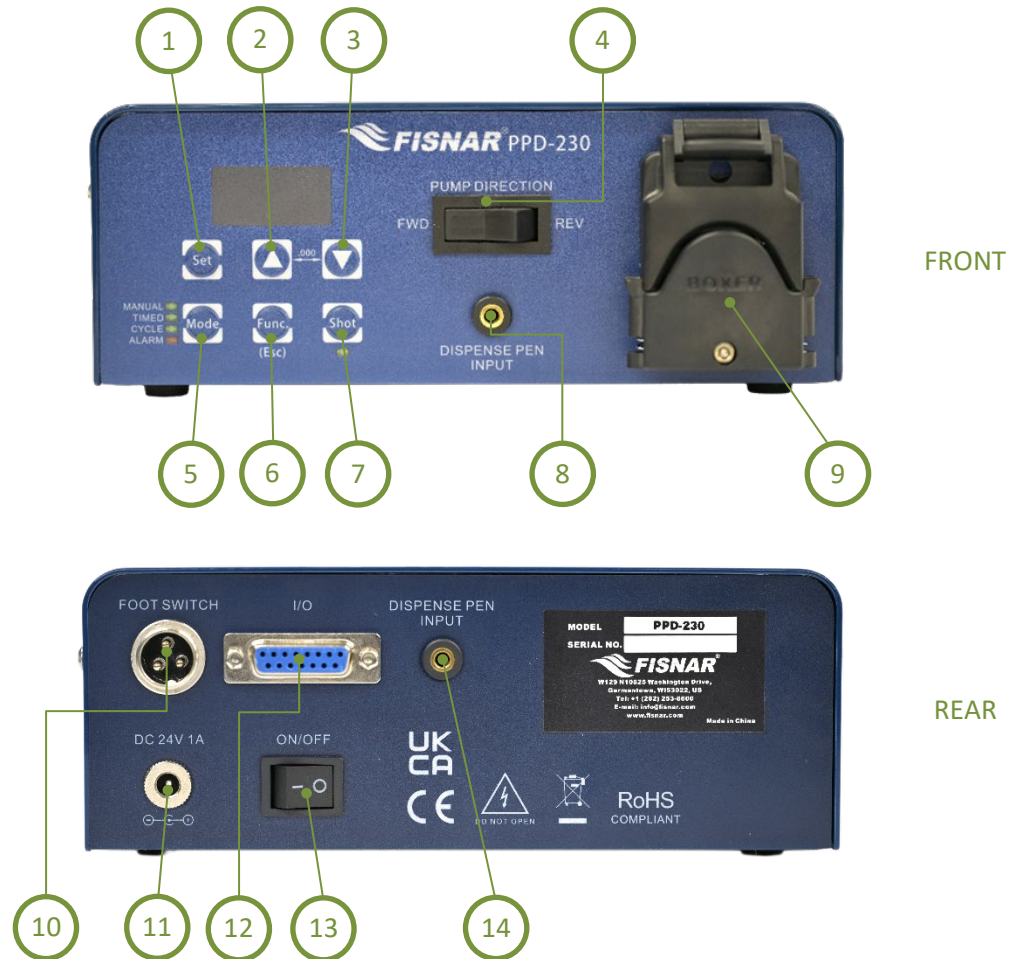

**FIG. 1: External Controls – Overview**

Item	Illustration	Item	Illustration	Item	Illustration
1	Set Button	7	Shot Button	13	Power On/Off Switch
2	Scroll Up Button	8	Dispense Pen Connector	14	Dispense Pen Connector
3	Scroll Down Button	9	Pump Head		
4	Pump Direction Switch	10	Foot Switch Connector		
5	Mode Button	11	Power Input Connector		
6	Function Button	12	I/O Connector		

## EXTERNAL CONTROLS

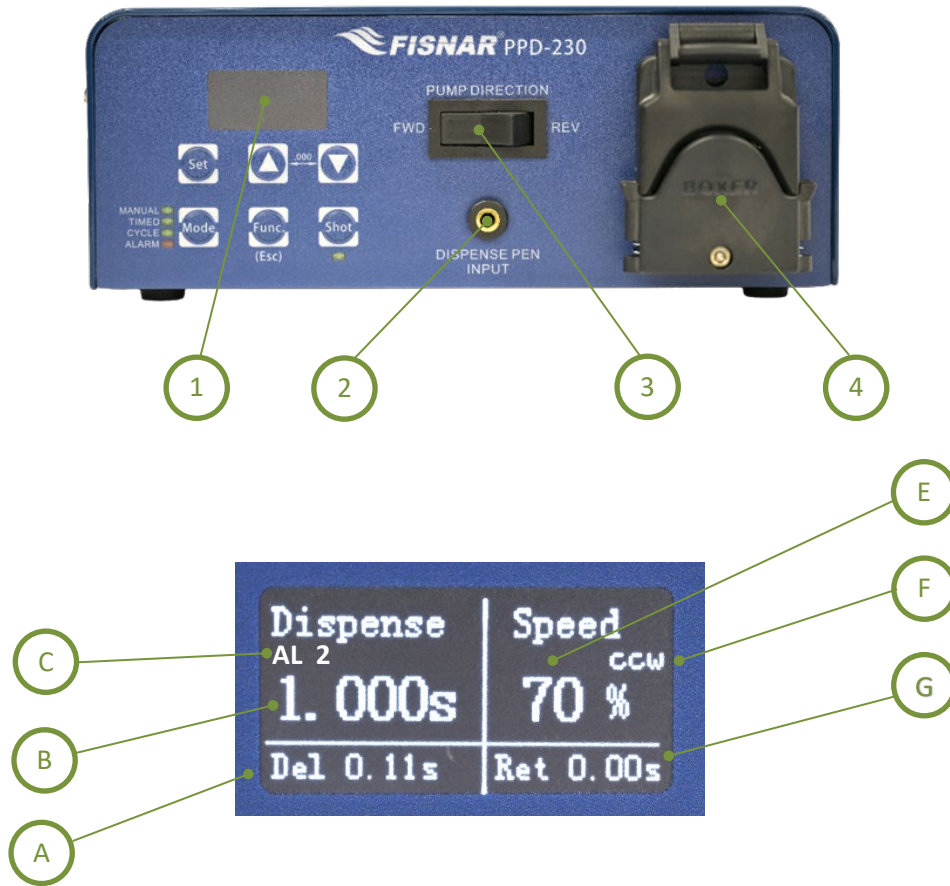

**FIG. 2: External Controls – Front**

<p><b>1A.</b></p>	<p><b>Digital Display Screen – Delay Time</b></p>	<p>Displays the Delay Time that the pump head will remain idle for after executing the “dispense time” command, and before starting the “retract time” command.</p> <p>Typically, this function is used to allow the dispensed fluid to settle onto the substrate before executing a “retract time” command</p>
<p><b>1B.</b></p>	<p><b>Digital Display Screen – Dispense Time</b></p>	<p>In MANUAL mode, when the push button switch on the dispense pen or “SHOT” button is pressed, or an external machine actuation input signal is received, the pump head will be actuated to start dispensing fluid. The machine will also begin counting up from 0.000 seconds.</p> <p>When the push button switch on the dispense pen or “SHOT” button is released, or an external machine actuation input signal is removed, the pump head will stop being actuated and dispensing of fluid will stop. The machine will display and hold the dispense cycle time until the next actuation cycle.</p>

		<p>When the push button switch on the dispense pen or “SHOT” button is pressed again, or an external machine actuation input signal received again, the timer will automatically reset and start counting up from 0.000 seconds, and the auger valve will be actuated to start dispensing fluid again.</p> <p>in TIMED mode, the saved dispense time (seconds) will be displayed. When the push button switch on the dispense pen or “SHOT” button is pressed, or an external machine actuation input signal is received, the pump head will be actuated to start dispensing fluid. The machine will also begin counting up from 0.000 seconds until it reaches the saved dispense time.</p> <p>Once the saved dispense time has been reached, the pump head will stop being actuated and dispensing of fluid will stop. The machine will display the saved dispense time until the next actuation cycle.</p> <p><b>One (1) individual program is saved to the machine and automatically recalled when the machine is powered on.</b></p> <p>in CYCLE mode, the saved dispense time (seconds) will be displayed. When the push button switch on the dispense pen or “SHOT” button is pressed, or an external machine actuation input signal is received, the pump head will be actuated to start dispensing fluid. The machine will also begin counting up from 0.000 seconds until it reaches the saved dispense time.</p> <p>Once the saved dispense time has been reached, the pump head will stop being actuated and dispensing of fluid will stop. The machine will then automatically start counting down from the time set in the “P00. Auto Cycle Stop” function setting to 0.000 seconds.</p> <p>Once the machine has counted down to 0.000 seconds, the pump head will automatically be actuated to start dispensing fluid again. The machine will also automatically begin counting up from 0.000 seconds until it reaches the saved dispense time.</p> <p>This looping cycle will continue to be repeated until the push button switch on the dispense pen or “SHOT” button is pressed again, or an external machine actuation input signal is received again.</p>
<p>1C.</p>	<p><b>Digital Display Screen - Alarm</b></p>	<p>If an alarm circuit is activated, it will be displayed here.                  AL 2 = External Error Input Alarm                  AL 3 = Pump Head Motor Overload Alarm</p> <p>A red LED light will illuminate next to the text “ALARM” on the front panel of the controller, to identify the “Alarm Out” signal has been activated.</p> <p>If the “Alarm Out” signal is activated during a program cycle, the</p>

		<p>program cycle will be automatically stopped.</p> <p>It will also not be possible to actuate a new program cycle until the “Alarm Out” signal has been switched off.</p>
1E.	<b>Digital Display Screen – Motor Speed</b>	The speed that the pump head motor will rotate during the dispense time cycle is displayed here.
1F.	<b>Digital Display Screen – Motor Direction</b>	The pump head motor direction for carrying out the dispense time cycle, which is set according to the position of the “Pump Direction” switch is displayed here.
1G.	<b>Digital Display Screen – Retract Time</b>	<p>Displays the Retract Time that the pump head will rotate in the opposite direction after executing the “dispense time” command, and “delay time” command (if set).</p> <p>Typically, this function is used to control/eliminate fluid dripping from the dispense tip, after the dispense actuation cycle has been completed in order to create a clean cut off.</p>
2.	<b>Dispense Pen Input</b>	The electrical connector of the dispense pen assembly is connected here. (Alternatively, it can be connected to the Dispense Pen Input on the back panel of the machine)
3.	<b>Pump Direction Switch</b>	<p>The pump direction switch controls the rotational direction of the motor in the pump head assembly when the push button switch on the dispense pen or “SHOT” button is pressed.</p> <p>FWD = The motor of the pump head will rotate in a counterclockwise direction as viewed when looking at the front of the machine. In this position, fluid will be dispensed out of the tubing and onto the workpiece from the fluid reservoir.  <i>(This is based on the tubing being loaded into the pump head from right to left)</i></p> <p>REV = The motor of the pump head will rotate in a clockwise direction as viewed when looking at the front of the machine. In this position fluid will be retracted through the tubing and back into the fluid reservoir.  <i>(This is based on the tubing being loaded into the pump head from right to left)</i></p>
4.	<b>Pump Head</b>	<p>The fluid tubing between the fluid reservoir and dispense pen is installed here. (See Appendix 2)</p> <p>It is recommended that the fluid tubing is installed from right to left. I.E. the tubing comes from the fluid reservoir and enters the right side of the pump head. The fluid tubing then exits the left side of the pump head and into the dispense pen assembly.</p>

## EXTERNAL CONTROLS

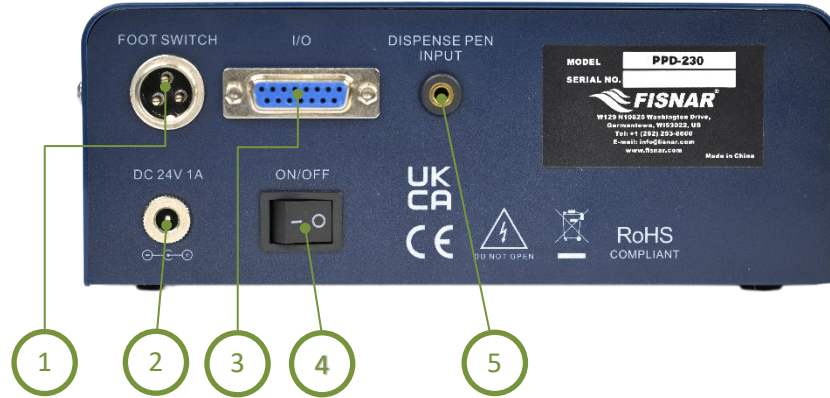









**FIG. 3: External Controls - Back**







1.	<b>Foot Switch Connector</b>	<p>If it is not suitable/desirable for the push button switch on the dispense pen assembly to be used to actuate the dispense cycle, a foot pedal switch (#5601888 sold separately) can be connected here to actuate the dispense cycle instead.</p> <p>Or it can be used for connecting to an external device (e.g. Fisnar dispense robot), which will send the dispense start actuation signal to the machine.</p>
2.	<b>Power Input Connector</b>	The power input cable from the external power supply is connected here.
3.	<b>I/O Connector</b>	<p>Where the external machine I/O input signals and output signals are connected.</p> <p>A courtesy 24V + output is also included on the I/O Connector.</p>
4.	<b>On / Off Switch</b>	Used to switch the machine on or off.
5.	<b>Dispense Pen Input</b>	The electrical connector of the dispense pen assembly can be connected here. (Alternatively, it can be connected to the Dispense Pen Input on the front panel of the machine)

## EXTERNAL CONTROLS



FIG. 4: Control Buttons

<p><b>Mode</b></p>	<p>Press the  button to switch between the three different dispense modes (MANUAL, TIMED or CYCLE). A green LED light will illuminate next to the text “MANUAL”, “TIMED” or “CYCLE”, to identify the current dispense mode that the machine is operating in.</p>
<p><b>Set</b></p>	<p>When in “TIMED” or “CYCLE” mode Press the  button to change the dispense time using the  and/or  button. When adjusting the dispense time, the  button is used as a scroll button to move between the numerical digits showing on the digital display screen.</p> <p>When the machine is in the “FUNCTION” menu, the  button is used to go into and out of the selected function setting.</p>
<p><b>UP and DOWN</b></p>	<p>When adjusting the setting on the home screen, press the  and/or  button to increase or decrease the displayed numerical value.</p>

	<p>When the machine is in the “FUNCTION” menu, the  and/or  button is used to scroll through the different Function settings.</p> <p>When the machine is in a function setting, press the  and/or  button to adjust the function setting as required.</p>
<p><b>Shot</b></p>	<p>Press the  button to actuate the machine and begin dispensing fluid.</p>
<p><b>Func. (Esc)</b></p>	<p>Press and hold the  button for 2 seconds to enter the Function Menu to make changes to the Function settings, which provide additional control and adjustment to the dispense application and machine settings.</p>

## MACHINE SET UP

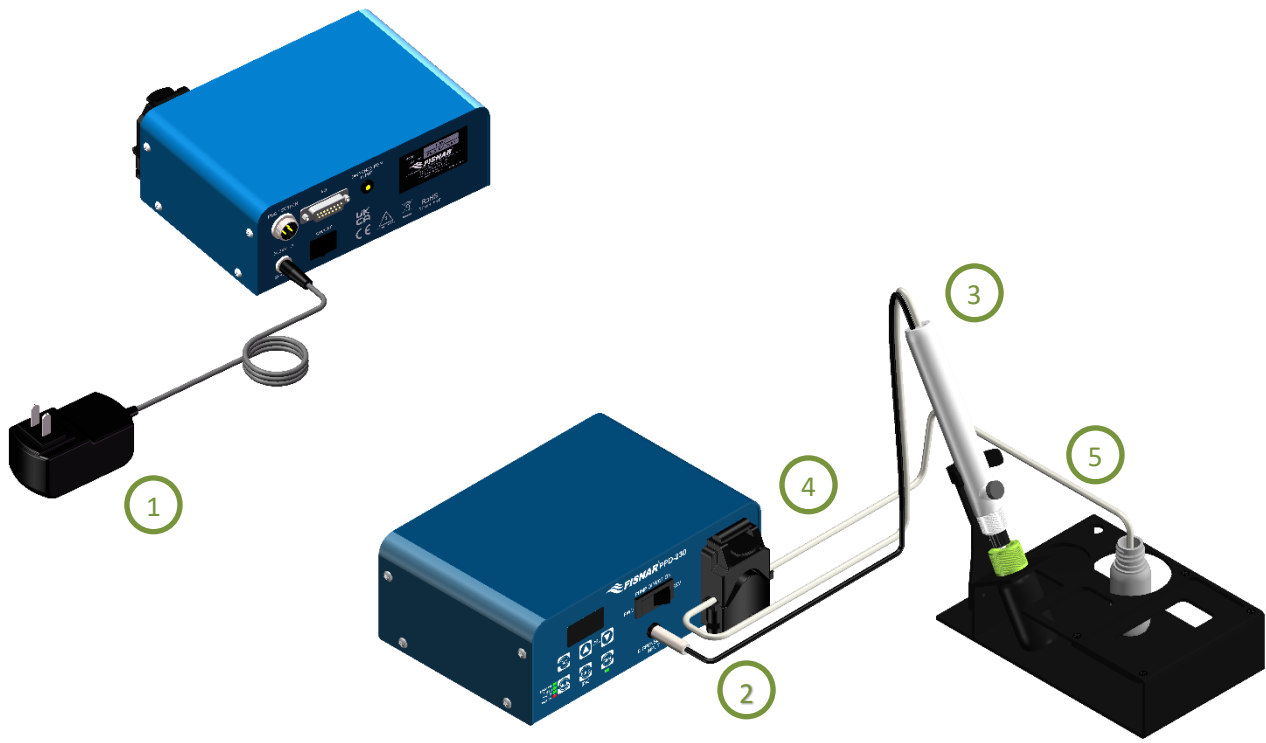
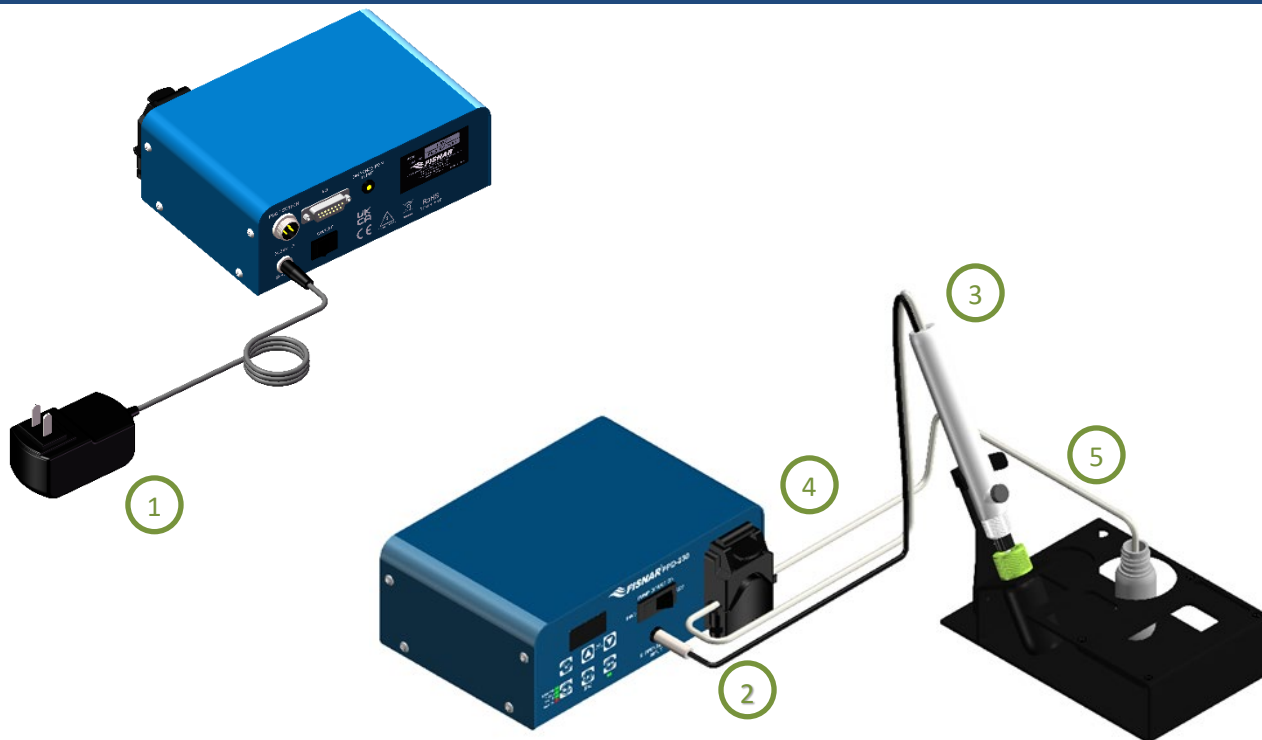

FIG. 5: Machine Setup

- |    |                                                                                                                                                                                                                                                                                                                                                                                                                                                                                              |
|----|----------------------------------------------------------------------------------------------------------------------------------------------------------------------------------------------------------------------------------------------------------------------------------------------------------------------------------------------------------------------------------------------------------------------------------------------------------------------------------------------|
| 1. | Attach the appropriate country type plug adapter onto the power supply and then connect the Electrical Power Cord (3) to the power input connector on the back of the machine.                                                                                                                                                                                                                                                                                                               |
| 2. | <p>Insert the electrical connector on the dispense pen assembly (2) into the “Dispense Pen Input” port on the front of the machine. Alternatively, it can be plugged into the “Dispense Pen Input” port on the back of the machine.</p> <p>Or connect the cable from the dispenser port of the Fisnar robot into the “Foot Switch” port on the back of the machine. Alternatively, the machine can be actuated by an external device using the I/O connector on the back of the machine.</p> |

## DISPENSE SETUP









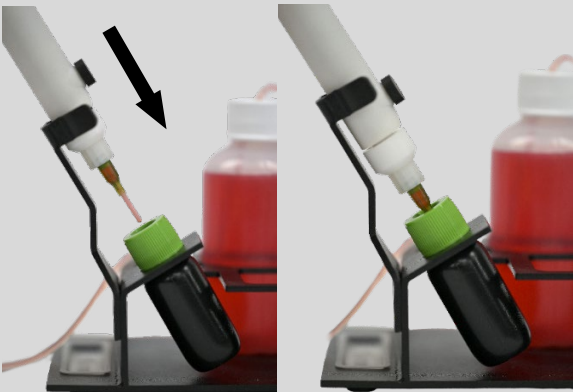

**FIG. 6: Dispense Setup**

Install the tubing into the dispense pen (3) and attach a suitable dispense tip. (See Appendix 1) Then, place it into the dispense pen holder on the stand.

### Tubing Selection

1. Innovaprene™ 1.0mm I.D. x 3.0mm O.D. Tubing (#5602013):- Use for fluids that react / cure in UV or visible light and when fluid viscosity is <100Cps or when a slow flow rate is desired.
1. Innovaprene™ 2.0mm I.D. x 4.0mm O.D. Tubing (#5602015):- Use for fluids that react / cure in UV or visible light and when fluid viscosity is >100Cps or when a high flow rate is desired.
- Innovasil™ 1.0mm I.D. x 3.0mm O.D. Tubing (#5602012):- Use for fluids that do not react / cure in UV or visible light and when fluid viscosity is <100Cps or when a slow flow rate is desired.
- Innovasil™ 2.0mm I.D. x 4.0mm O.D. Tubing (#5602014):- Use for fluids that do not react / cure in UV or visible light and when fluid viscosity is >100Cps or when a high flow rate is desired.

2.	Install the tubing into the pump head (4). (See Appendix 2)
3.	Install the tubing into the fluid reservoir (5). (See Appendix 3) Then place it into the appropriate retaining hole on the stand.
4.	Power on the machine and check the operation mode of the machine is set to “Manual” mode.
5.	Check the “Pump Direction” on the front panel of the machine is set to the “FWD (forward)” position.
6.	<p>Follow the procedure below to set the speed that the pump head motor will run at during the dispense time cycle.</p> <p>Press the  button to enter into the main display screen.</p> <p>Press the  button until the values below the “Speed” (pump head motor speed) are flashing.</p> <p>Press the   buttons to adjust and set the value to 50%.</p> <p>Allow the digits on the display screen to continue flashing. After 5 seconds, the digits will stop flashing and the pump head motor speed shown on the display will be saved.</p>
7.	<p>Press and hold the push button switch on the dispense pen or  button to start the dispense actuation of the machine.</p> <p>Fluid will slowly begin to fill the tubing between the fluid reservoir and the dispense pen, and then flow out of the dispense tip. If using Inovasil™ tubing the flow of fluid in the tubing will be clearly visible.</p> <p>When fluid is consistently flowing from the dispense tip at a steady rate and no bubbles/air-pockets are observed, release the push button switch on the dispense pen or  button on the front of the machine.</p> <p>If no fluid is dispensed from dispense tip after approx. 1-2 minutes stop the actuation of the machine. The below steps can then be carried out, and the machine actuated again.</p> <ol style="list-style-type: none"> <li>Increase motor speed.</li> <li>Remove dispense tip.</li> <li>Check fluid tubing is located at the bottom of the fluid reservoir being used.</li> <li>Check fluid tubing is correctly installed into the pump head.</li> </ol> <p>If fluid is still not dispensed, please contact your local sales representative.</p>

<p>8.</p>	<p>Use the parameters below to fine tune and optimize the dispensing application.</p> <ol style="list-style-type: none"> <li>1.) Adjust the pump speed and dispense tip size to set the required flow rate.</li> <li>2.) Adjust the dispense time and dispense tip size to set the required dispense volume.</li> </ol>
<p>9.</p>	<p>If drooling/stringing of fluid is visible after the dispense actuation cycle has been completed, go into the display settings to adjust and set the delay time and retract time as needed to mitigate this effect. The retract speed is adjusted and set in the Function settings menu (P04. Retract Speed).</p> <p><b>Note:- When using a Retract Time, we recommend also using a small Delay Time, so that the last of the fluid can flow out of the dispense tip, before the Retract Time applies a small suck-back / shearing effect to the fluid contained within the dispense tip.</b></p>
<p>10.</p>	<p>When not being used, the dispense pen (3) should be placed in the stand provided. This will prevent the dispense tip from being accidentally damaged.</p> <p>The bottle it is placed into, allows any fluid that drips from the dispense tip to be safely captured. The dispense tip is also protected in the bottle from any foreign contaminants or environmental lighting that may affect the properties of the fluid within it.</p> 
<p>11.</p>	<p>Purge trays (#5601970) are provided with the stand to allow for a small amount of fluid to be purged into a clean and contained location. This is also helpful when a new dispense tip is attached to the dispense pen or when checking for accurate fluid material flow.</p> 

## DISPENSE MODES



FIG. 7: Dispense Mode - Manual

## MANUAL MODE

1.



Use the  button to switch to MANUAL mode. The green light on the front of the machine next to the text “MANUAL” will illuminate.

MANUAL mode allows the operator to actuate the machine on demand whenever the push button switch on the dispense pen or “SHOT” button is pressed.

MANUAL mode can also be used to allow an externally connected device to control the dispense actuation and time signal duration of the machine.

2.

Follow the procedure below to set the speed that the pump head motor will run at during the dispense time cycle.



Press the  button to enter into the main display screen.









Press the  button until the values below the “Speed” (pump head motor speed) are flashing.





Press the  buttons to adjust and set the value (0-100%)

Once the correct pump head motor speed has been set, allow the digits on the display screen to continue flashing. After 5 seconds, the digits will stop flashing and the pump head motor speed shown on the display will be automatically saved.

<p>3.</p>	<p>Follow the procedure detailed below to set the Delay Time that the pump head will remain idle for after executing the “dispense time” command, and before starting the “retract time” command.</p> <p>Typically, this function is used to allow the dispensed fluid to settle onto the substrate before executing a “retract time” command</p> <p>Press the  button to enter into the main display screen</p> <p>Press the  button until the values next to “Del” (Delay Time) are flashing.</p> <p>Press the  buttons to adjust and set the value (0-9.99s)</p> <p>Once the correct delay time has been set, allow the digits on the display screen to continue flashing. After 5 seconds, the digits will stop flashing and the delay time shown on the display will be automatically saved.</p> <p><b>Note:- This step can be ignored if the application does not require a delay time.</b></p>
<p>4.</p>	<p>Follow the procedure detailed below to set the Retract Time that the pump head will rotate in the opposite direction after executing the “dispense time” command, and “delay time” command (if set).</p> <p>Typically, this function is used to control/eliminate fluid dripping from the dispense tip, after the dispense actuation cycle has been completed in order to create a clean cut off.</p> <p>Press the  button to enter into the main display screen</p> <p>Press the  button until the values next to “Ret” (Retract Time) are flashing.</p> <p>Press the  buttons to adjust and set the value (0-9.99s)</p> <p>Once the correct retract time has been set, allow the digits on the display screen to continue flashing. After 5 seconds, the digits will stop flashing and the delay time shown on the display will be automatically saved.</p> <p><b>Note:- This step can be ignored if the application does not require a retract time.</b></p>

5.

Press the push button switch on the dispense pen,  button, or supply an external machine actuation input signal to start the machine and begin dispensing. Release the push button switch on the dispense pen or  button or remove an external machine actuation input signal to stop dispensing.

The machine will count the amount of time you are dispensing while the push button switch on the dispense pen or  button is pressed, or an external machine actuation input signal is held on for.

This may be helpful in determining a dispense time to be used for achieving the required dispense volume when actuating the machine in TIMED mode.

The TIME shown on the digital display after the push button switch on the dispense pen or  button, or external machine actuation input signal has been released, will reset to zero (0) seconds every time the machine is actuated.

## DISPENSE MODES



FIG. 8: Dispense Mode - Timed

### TIMED MODE

Use the  button to switch to TIMED mode. The green light on the front of the machine next to the text “TIMED” will illuminate.

TIMED mode allows the operator to dispense fluid for a set time period, regardless of how long the push button switch on the dispense pen or  button is pressed.

1.



TIMED mode can also be used to allow an externally connected device to control the dispense actuation by sending an initial momentary signal. The machine will then control the time period that fluid is dispensed for.

Follow the procedure detailed below to set the Dispense Time that the pump head will rotate and fluid will be dispensed for.



Press the  button to enter into the main display screen

If the dispense time is being set for the first time the first digit on the left side of the display will start flashing, or if the dispense time is being reset, then the last digit position changed previously will start flashing.

Press the  button until the values below “Dispense” (Dispense Time) are flashing.

Press the   buttons to adjust the value (0-9). The digit that is flashing in the display screen is the one that will be adjusted.

2.







Press the  button again to move to the next digit to the right of the one that was previously flashing. Adjust accordingly to the correct numerical value using the   buttons.





Continue to press the  button to scroll through the digit positions, adjusting the numerical values as required.

When the  button is pressed when the fourth (last) digit is flashing the first numerical digit will start flashing, allowing you to cycle through the digit positions again, in a continuous cycle.

Once the correct dispense time has been set, allow the digits on the display screen to continue flashing. After 5 seconds, the digits will stop flashing and the dispense time shown on the display will be automatically saved.

Note that if the  button or   buttons are not pressed again within 5 seconds, the digits will stop flashing and the dispense time shown on the display will be automatically saved.



<p>3.</p>	<p>Follow the procedure below to set the speed that the pump head motor will run at during the dispense time cycle.</p> <p>Press the  button to enter into the main display screen.</p> <p>Press the  button until the values below the “Speed” (pump head motor speed) are flashing.</p> <p>Press the  buttons to adjust and set the value (0-100%)</p> <p>Once the correct pump head motor speed has been set, allow the digits on the display screen to continue flashing. After 5 seconds, the digits will stop flashing and the pump head motor speed shown on the display will be automatically saved.</p>
<p>4.</p>	<p>Follow the procedure detailed below to set the Delay Time that the pump head will remain idle for after executing the “dispense time” command, and before starting the “retract time” command.</p> <p>Typically, this function is used to allow the dispensed fluid to settle onto the substrate before executing a “retract time” command</p> <p>Press the  button to enter into the main display screen</p> <p>Press the  button until the values next to “Del” (Delay Time) are flashing.</p> <p>Press the  buttons to adjust and set the value (0-9.99s)</p> <p>Once the correct delay time has been set, allow the digits on the display screen to continue flashing. After 5 seconds, the digits will stop flashing and the delay time shown on the display will be automatically saved.</p> <p><b>Note:- This step can be ignored if the application does not require a delay time.</b></p>



<p>5.</p>	<p>Follow the procedure detailed below to set the Retract Time that the pump head will rotate in the opposite direction after executing the “dispense time” command, and “delay time” command (if set).</p> <p>Typically, this function is used to control/eliminate fluid dripping from the dispense tip, after the dispense actuation cycle has been completed in order to create a clean cut off.</p> <p>Press the  button to enter into the main display screen</p> <p>Press the  button until the values next to “Ret” (Retract Time) are flashing.</p> <p>Press the   buttons to adjust and set the value (0-9.99s)</p> <p>Once the correct retract time has been set, allow the digits on the display screen to continue flashing. After 5 seconds, the digits will stop flashing and the delay time shown on the display will be automatically saved.</p> <p><b>Note:- This step can be ignored if the application does not require a retract time.</b></p>
<p>6.</p>	<p>Press the push button switch on the dispense pen,  button, or supply a momentary external machine actuation input signal to start the machine and begin dispensing.</p> <p>The dispense time counter on the digital display will automatically start counting up from 0.000 seconds until it reaches the saved dispense time.</p>
<p>7.</p>	<p>The machine will continue dispensing until the saved dispense time is reached.</p>
<p>8.</p>	<p>When the saved dispense time is reached the machine will automatically stop dispensing.</p>

**SETTING A DISPENSE TIME GREATER THAN 9.999 SECONDS.**



Press the  button to enter into the main display screen

Press the  button until the values below “Dispense” (Dispense Time) are flashing. Continue to press the  button to scroll to the first digit position.

Press the  button to increase the numerical value upwards. Once the numerical value “9” is displayed, press the  button one more time.

**NOTES**



The first digital numerical value will change to “1”, the second digit numerical value will change to “0” and the decimal point “.” will automatically move from being displayed after the first digit position to after the second position.



The numerical value that was originally in the second digit position will move to the third digit position, and the numerical value that was originally in the third digit position will move to the fourth (last) digit position.

The numerical value that was originally in the fourth digit position will now not be shown and be disregarded.



NOTES

**REDUCING A DISPENSE TIME FROM GREATER THAN 10.00 SECONDS**



Press the  button to enter into the main display screen. Press the  button until the values below “Dispense” (Dispense Time) are flashing.

Continue to press the  button to scroll to the first digit position.

Press the  button to decrease the numerical value downwards until the numerical value “1” is displayed. Press the  button to scroll to the second digit position. use  button to decrease the numerical value downwards.

Once the numerical value “0” is reached, press the  button one more time.



The first digital numerical value will automatically change to “9”, the second digit numerical value will change to the numerical value that was originally displayed in the third digit position.

The third digit numerical value will change to the numerical value that was originally displayed in the fourth digit position.

The fourth digit numerical value will change to the numerical value that was originally displayed in the fourth digit position when the dispense time was changed to a dispense time greater than 9.999 seconds.

## DISPENSE MODES



FIG. 9: Dispense Mode - Cycle

## CYCLE MODE

1.



Use the  button to switch to CYCLE mode. The green light on the front of the machine next to the text “CYCLE” will illuminate.

CYCLE mode allows the operator to create a repeating cycle of dispensing actuations.

For example, if you would like to dispense for 1 second then wait for 5 seconds and cycle these times over and over again.























Press the  button to enter into the main display screen

If the dispense time is being set for the first time the first digit on the left side of the display will start flashing, or if the dispense time is being reset, then the last digit position changed previously will start flashing.



Press the  button until the values below “Dispense” (Dispense Time) are flashing.







	<p>Press the   buttons to adjust the value (0-9). The digit that is flashing in the display screen is the one that will be adjusted.</p> <p>Press the  button again to move to the next digit to the right of the one that was previously flashing. Adjust accordingly to the correct numerical value using the   buttons.</p> <p>Continue to press the  button to scroll through the digit positions, adjusting the numerical values as required.</p> <p>When the  button is pressed when the fourth (last) digit is flashing the first numerical digit will start flashing, allowing you to cycle through the digit positions again, in a continuous cycle.</p> <p>Once the correct dispense time has been set (e.g. 1.000), allow the digits on the display screen to continue flashing. After 5 seconds, the digits will stop flashing and the dispense time shown on the display will be automatically saved.</p> <p>Note that if the  button or   buttons are not pressed again within 5 seconds, the digits will stop flashing and the dispense time shown on the display will be automatically saved.</p>
<p>2.</p>	<p>Press and hold the  key for 3 seconds to enter the Function menu.</p> <p>Press the  or  button to navigate to the Function Setting P00. Auto Cycle Stop.</p> <p>Press the  button to enter the Function setting to make a change.</p>

	<p>Press the  or  button to adjust the Auto Cycle Stop Time as required, e.g., 5.000.</p> <p>Press the  button to exit the selected Function setting.</p> <p>Press and hold the  key for 3 seconds to exit the Function menu.</p>
<p>3.</p>	<p>Press the push button switch on the dispense pen,  button, or supply a momentary external machine actuation input signal to start the machine and begin dispensing.</p> <p>The digital display will automatically start counting up from 0.000 seconds until it reaches the saved dispense time.</p>
<p>4.</p>	<p>The machine will continue dispensing until the saved dispense time is reached.</p>
<p>5.</p>	<p>When the saved dispense time is reached the pump head will stop being actuated and dispensing of fluid will stop.</p>
<p>6.</p>	<p>The machine will then automatically start counting down from the time set in the “Auto Cycle Stop Time” setting saved in the Function Menu to 0.000 seconds.</p>
<p>7.</p>	<p>Once the machine has counted down to 0.000 seconds, the pump head will automatically be actuated to start dispensing fluid again. The machine will also automatically begin counting up from 0.000 seconds until it reaches the saved dispense time.</p>
<p>8.</p>	<p>This looping cycle will continue to be repeated until the push button switch on the dispense pen or  button is pressed again, or a momentary external machine actuation input signal is received again.</p>

## FUNCTION MENU

The machine offers built-in functions that provide additional control and adjustment to the dispense application and machine settings.

**Instructions:**

1. Press and hold the  key for 3 seconds to enter the Function menu.
2. Press the  or  button to scroll through the available settings.
3. Press the  button to enter the selected Function setting to make a change.
4. Press the  or  button to adjust the setting as required.
5. Press the  button to exit the selected Function setting.
6. Press and hold the  key for 3 seconds to exit the Function menu.

**Overview:**

Function Setting	Description
P00. Auto Cycle Stop	Sets the time that the pump head will remain idle for after executing a program cycle, and before starting the next program cycle, when the machine is in "CYCLE" mode.
P04. Retract Speed	Sets the speed that the pump head will rotate in the opposite direction, during the execution of the Retract Time.
P09. Manual Actuation Switch Type	Sets if the dispense actuation signal will work as a momentary "0" or latching "1" type.
P14. Motor Current Overload Alarm	Switches on or off the Motor Current Overload Alarm.

P15. Lock Screen	When activated the operator is prevented from making any adjustments to the machine settings on the home screen. The Function menu also becomes password protected.
P20. Program Version	Displays the software version installed on the machine.
P21. Dispense Count	Displays the total number of completed dispense cycles. This counter is resettable.
P22. Total Machine Cycles	Displays the total number of completed dispense cycles made by the machine. This counter is not resettable.
P23. Total Dispense Time	Displays the total number of minutes the machine has been actuated for. This counter is not resettable.
P24. Language	Selects the language displayed on the machine.

## FUNCTION MENU

### P00. Auto Cycle Stop

This function is only used when the machine is in “CYCLE” mode. It allows the user to set a delay time in between one program cycle ending and the next program cycle automatically starting.

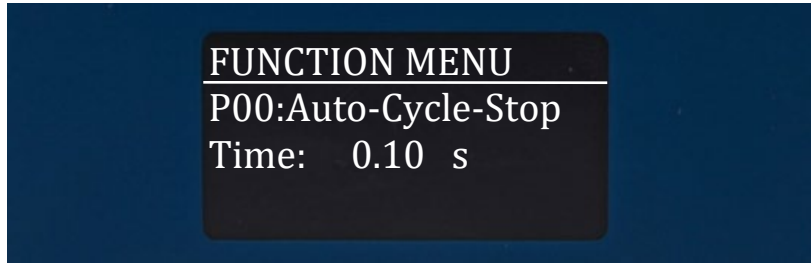







Fig. 10: Auto Cycle Stop

1	When the Auto Cycle Stop page is displayed, press the  button to enter the setting page for the Auto Cycle Stop function.
2	Press the  or  buttons to set the required time in seconds.
3	Press the  button to exit the selected Function setting.
4	Press and hold the  key for 3 seconds to exit the Function menu.

## FUNCTION MENU



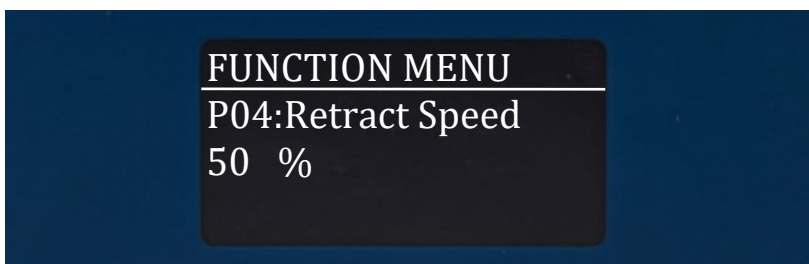

### P04. Retract Speed

This function allows the user to set a Retract Speed that the pump head will rotate in the opposite direction, during the execution of the Retract Time.

The value is set as a percentage value from 1% - 100% and is directly related to the output voltage supplied to pump head. I.E. 10% = 2.4V, 50% = 12V, 100% = 24V. (A low percentage value will result in a slow retract speed of the pump head. A high percentage value will result in a fast retract speed of the pump head.)



**Fig. 11: Retract Speed**

1	When the Retract Speed page is displayed, press the  button to enter the setting page for the Retract Speed function.
2	Press the  or  buttons to set the required dispensing speed of the pump head.
3	Press the  button to exit the selected Function setting.
4	Press and hold the  key for 3 seconds to exit the Function menu.

## FUNCTION MENU

### P09. Manual Actuation Switch Type

This function sets if the dispense actuation signal will work as a momentary or latching type when the machine is set to "MANUAL" mode.

**Momentary (0) =** When in MANUAL Mode, the machine will actuate for as long as the dispense actuation signal is received. When the dispense actuation is not received the machine will stop actuating.

**Latching (1) =** When in MANUAL Mode, the machine will actuate for as long as the dispense actuation signal is received. When the dispense actuation is not received the machine will continue to actuate. When the next dispense actuation signal is received the machine will stop actuating.

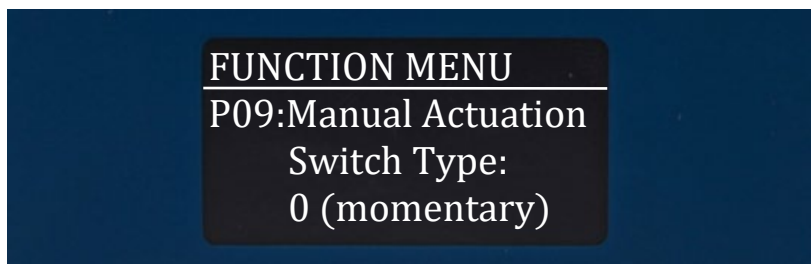







Fig. 12: Manual Actuation Switch Type

1	<p>When the Manual Actuation Switch Type page is displayed, press the  button to enter the setting page for the Manual Actuation Switch Type function. 0 = momentary / 1 = latching</p>
2	<p>Press the  or  buttons to set the required switch type.</p>
3	<p>Press the  button to exit the selected Function setting.</p>
4	<p>Press and hold the  button for 3 seconds to exit the Function menu.</p>

## FUNCTION MENU

### P14. Motor Current Overload Alarm

This function allows the user to enable the Motor Current Overload Alarm function on the controller.

By enabling this function, the motor current overload alarm will only be activated during a program cycle if the current draw to the pump head exceeds the default value (0.75A) set within the machine. If the motor current overload alarm is activated during a program cycle, the program cycle will be automatically stopped.



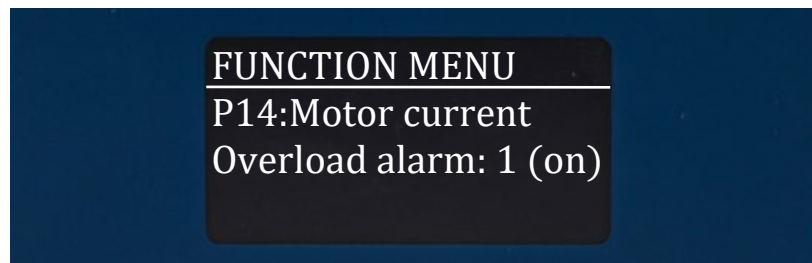

(Note:- The maximum allowable current draw value cannot be adjusted.)

When the motor current overload alarm is activated, A red LED light will illuminate next to the text “ALARM” on the front panel of the controller, and the text “AL3” will flash on the display screen. Pin #6 of the I/O output circuit will also be activated.

The motor current overload alarm will automatically reset when the current draw to the pump head falls below the default value set within the machine.



**Fig. 13: Motor Current Overload Alarm**





1	When Motor Current Overload Alarm is displayed, press the  button to enter the setting page for the Motor Current Overload Alarm function.
2	Press the  or  buttons to switch the Motor Current Overload Alarm On or Off.  0 = Off / 1 = On
3	Press the  button to exit the selected Function setting.
4	Press and hold the  key for 3 seconds to exit the Function menu.

## FUNCTION MENU

### P15. Lock Screen

This function allows the user to lock the machine controls preventing any adjustments to the settings on the home screen. The Function menu also becomes password protected.

When the Lock Screen is activated only the  button on the front panel of the machine will function. The  button will also become password protected.

To enter the Function menu when the Lock Screen is activated, press and hold the  button for 3 seconds. Use the  or  buttons to set the password number to "1985". Then press the  button. (Note, the password number cannot be changed.)

When the Lock Screen is activated, the text "L" will be displayed in the top right corner of the home screen.

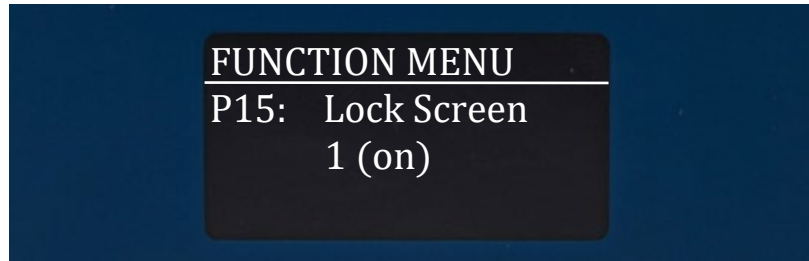







Fig. 14: Lock screen

1	When the Lock Screen page is displayed, press the  button to enter the setting page for the Lock Screen function.
2	Press the  or  buttons to switch the Lock Screen On or Off. 0 = Off / 1 = On
3	Press the  button to exit the selected Function setting.
4	Press and hold the  key for 3 seconds to exit the Function menu.

## FUNCTION MENU

### P20. Program Version

This function setting acts as an information page to confirm the firmware version installed onto the Timer Board (5601958-PPD230).

It is not possible to enter into this function setting.



Fig. 15: Program Version

## FUNCTION MENU

### P21. Dispense Count

This function displays the total number of completed dispense cycles made by the machine.

This counter is resettable

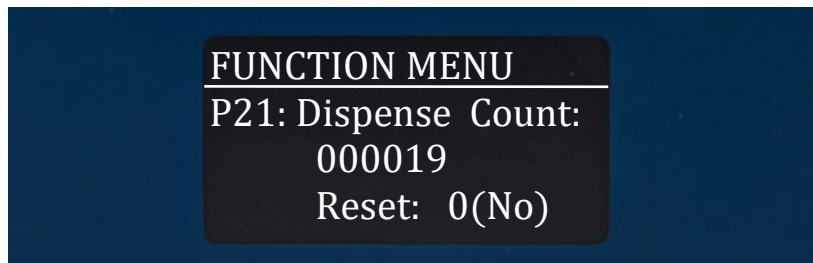









Fig. 16: Dispense Count

1	<p>When the Dispense Count page is displayed, press the  button to enter the setting page for the Dispense Count function.</p>
2	<p>Press the  or  buttons to change the value to 1 (Yes)</p> <p>If the Dispense Count page is entered into by mistake and the Dispense Count value should not be reset, press the  or  buttons to change the value to 0 (No)</p>
3	<p>Press the  button to exit the selected Function setting.</p> <p>If 1 (Yes) has been selected the Dispense Count value will automatically reset to zero during this sequence.</p>
4	<p>Press and hold the  key for 3 seconds to exit the Function menu.</p>

## FUNCTION MENU

### P22. Total Machine Cycles

This function displays the total number of completed dispense cycles made by the machine.

This counter is not resettable.

It is not possible to access this function setting.

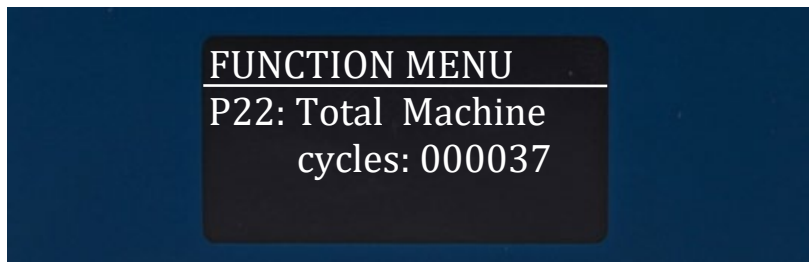

Fig. 17: Total Machine Cycle

## FUNCTION MENU

### P23. Total Dispense Time

This function displays the total number of minutes the machine has been actuated for.

Every dispensing cycle time from all modes is accumulated to the Dispense Time timer.

This counter is not resettable.

It is not possible to access this function setting.

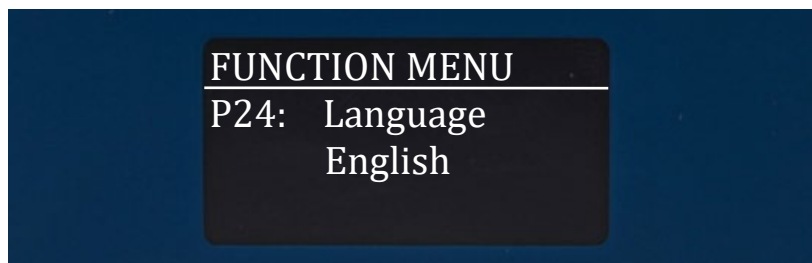

Fig. 18: Total Dispense Time





## FUNCTION MENU

### P24. Language

This function allows the user to select the language displayed on the machine.



**Fig. 19: Language**

1	When the Language page is displayed, press the  button to enter the setting page for the Language function.
2	Press the  or  buttons to set the required language. English / Chinese
3	Press the  button to exit the selected Function setting.
4	Press and hold the  key for 3 seconds to exit the Function menu.

## EXTERNAL MACHINE ACTUATION

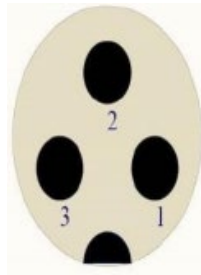

<u>Pin#</u>	<u>Description</u>
<u>1</u>	<u>NOM (Normally Open)</u>
<u>2</u>	<u>COM (Common)</u>
<u>3</u>	<u>Empty / Not Used</u>

FIG. 20: External Machine Actuation

<b>Input</b>	A dry contact closure (0 Volt) between the Input (Pin #1) and Common (Pin #2) pins will trigger a dispense signal.
	<p><b>PLEASE READ:</b></p> <p><b>Do not apply a voltage between the input pin (1) and the common pin (2). Doing so will damage the timer board and void all warranty conditions.</b></p>

## I/O Specifications – I/O Connector

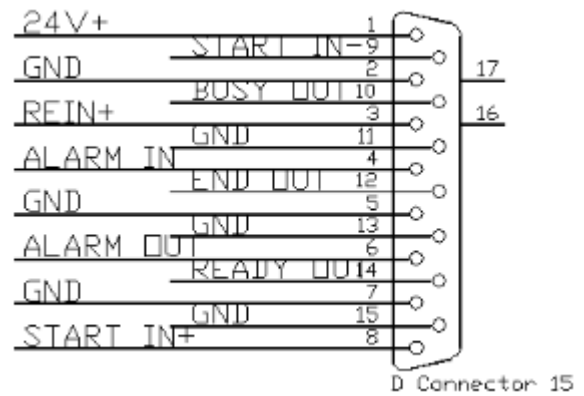
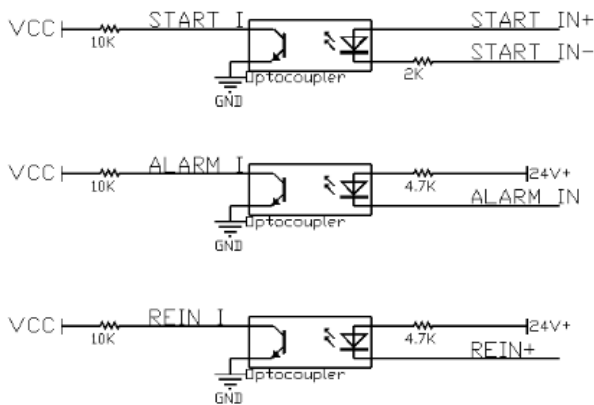
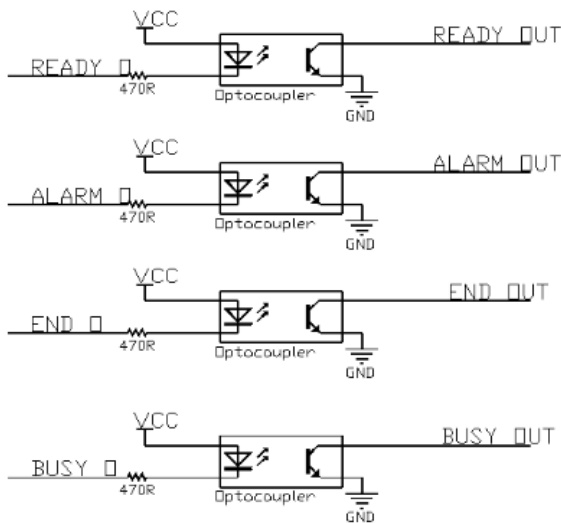
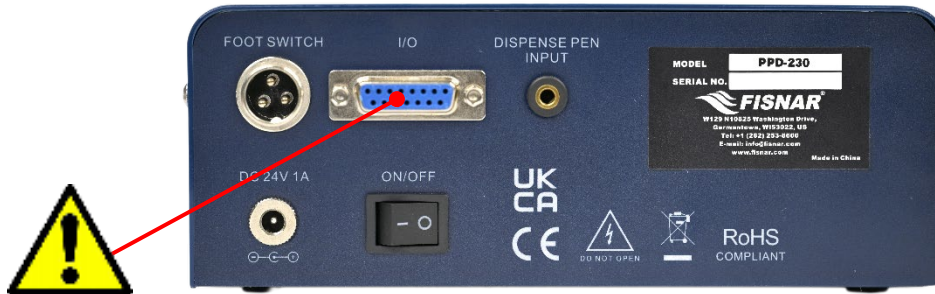

Pin #	Function
1	24V+ internal power OUT
2	GND internal ground
3	Contact Closure Initialize IN
4	Alarm IN
5	GND internal ground
6	Alarm OUT
7	GND internal ground
8	Start IN 24V+
9	Start IN GND (0V)
10	Machine Busy OUT
11	GND internal ground
12	End of Cycle OUT
13	GND internal ground
14	Machine Ready OUT
15	GND internal ground

FIG. 21: Input / Output Schematic

## OUTPUT SIGNALS

**Output Type:** Open Collector Optocoupler (NPN)

**Output Power:** Output signals are able to sink a maximum of 50 milliamps per pin.

**Output Function:** When the output signal is activated, the circuit between the output pin (pin #6, 10, 12 & 14) and the GND (pin #7, 11, 13 & 15) is completed.

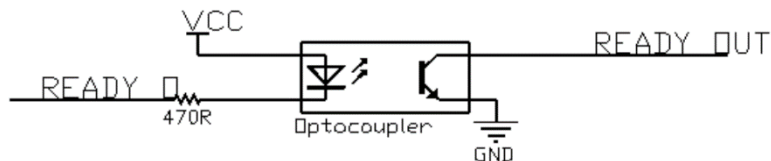

FIG. 22: Example of I/O output port driving



**PLEASE READ:** If an inductive load (such as a relay) is connected to an output signal, be sure to install a diode as shown to prevent damage to the output optocoupler.

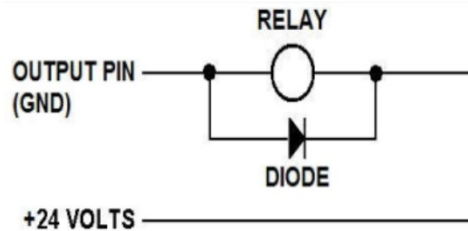

FIG. 23: Installation of Diode

## INPUT SIGNALS

**Input Type:** Opto-coupler

**Input Power:**

- Pin #3 and #4 are an externally driven dry-contact voltage free contact closure circuit (I.E. Switch or Relay).
- Pin #8 is an externally driven +24V DC voltage-initiated circuit.

**Input Function (pin #3, #4):**

- To activate an input signal, pull the input pin (pin #3, #4) down to a GND pin (pin #2, #5).
- Input signals utilize the controller internal power supply.

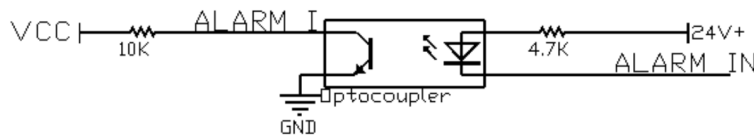

**FIG. 24: Example of I/O input port driving (pin #3, #4)**

**PLEASE READ:**



**A dry contact closure between inputs (pin #3 or pin #4) and any ground will trigger an input signal. DO NOT apply a voltage to input pin #3 or pin #4 and ground. Doing so will damage the internal control board and void all warranty conditions.**

**Input Function (pin #8):**

- To actuate the machine from an external device using a voltage signal (24V+),
  - o connect input pin "START IN +" (pin #8) to an external power supply (24V+).
  - o Connect input pin "START IN -" (pin #9) to an external GND (0V)

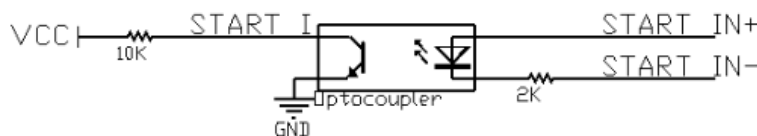

**FIG. 25: Example of I/O input port driving (pin #8)**

## OUTPUT SIGNAL DEFINITION

### Pin #6 Alarm Out (Output):

- The signal will be activated if any one of the below conditions occur.
  - o If the “Alarm In” input circuit has been activated.
  - o If the “Motor Current Overload Alarm” has been activated
- A red LED light will illuminate next to the text “ALARM” on the front panel of the controller, to identify the “Alarm Out” signal has been activated.
- If the “Alarm Out” signal is activated during a program cycle, the program cycle will be automatically stopped.
- It will also not be possible to actuate a new program cycle until the “Alarm Out” signal has been switched off.
- The signal will remain on until all the above conditions do not occur, whereby the signal and red LED light next to the text “ALARM” on the front panel of the controller, will then be automatically switched off.

### Pin #10 Machine Busy (Output):

- When the machine is actuating a program cycle (i.e. pump head is rotating and dispensing fluid) the signal will be activated.
- When the machine has completed the program cycle (i.e. pump head is not rotating and dispensing fluid) the signal will not be activated.

### Pin #12 End of Cycle (Output):

- When the machine has completed a program cycle (i.e. pump head has stopped rotating and dispensing fluid) the signal will be momentarily activated for a period of 10ms.

### Pin #14 Machine Ready (Output):

- After machine power on, the signal will be activated.
- The signal will automatically switch off if any of the below conditions occur.
  - o “Machine Busy” Output signal activated.
  - o “End of Cycle” Output signal activated.
  - o “Alarm Out” Output signal activated
- The signal will be re-activated automatically when all of the above conditions do not occur.

## INPUT SIGNAL DEFINITION

### Pin #3 CC Initialize (Input):

- When connected to a GND pin the “CC Initialize” signal will be activated, resulting in the machine program cycle being actuated.
  - o When in “MANUAL” mode, the machine will continue to be actuated (i.e. pump head is rotating and dispensing fluid) until “CC Initialize” signal is removed from the GND pin.
  - o When in “TIMED” mode, the machine will continue to be actuated (i.e. pump head is rotating and dispensing fluid) until the set dispense time on the machine has been reached.
  - o When in “CYCLE” mode, the machine will continue to be actuated (i.e. pump head is rotating and dispensing fluid) in a looping cycle until “CC Initialize” signal is removed from the GND pin and then re-applied.
  
- A green LED light will illuminate below the  button on the front panel of the controller, to identify the machine is actuating a program cycle (i.e. pump head is rotating and dispensing fluid).

### Pin #4 Alarm In (Input):

- When connected to a GND pin the “Alarm In” signal will be activated, resulting in the “Alarm Out” signal (Pin #6) being activated automatically.
- 

### Pin #8 Voltage Start IN+ (Input):

- When connected to an external 24V+ power supply, the “Voltage Initialize” signal will be activated, resulting in the machine program cycle being actuated.
  - o When in “MANUAL” mode, the machine will continue to be actuated (i.e. pump head is rotating and dispensing fluid) until “Voltage Initialize” signal is removed from the GND pin.
  - o When in “TIMED” mode, the machine will continue to be actuated (i.e. pump head is rotating and dispensing fluid) until the set dispense time on the machine has been reached.
  - o When in “CYCLE” mode, the machine will continue to be actuated (i.e. pump head is rotating and dispensing fluid) until “Voltage Initialize” signal is removed from the GND pin and then re-applied.
  
- A green LED light will illuminate below the  button on the front panel of the controller, to identify the machine is actuating a program cycle (i.e. pump head is rotating and dispensing fluid).



**PLEASE READ: For the “Voltage Start IN+” signal to work correctly, “Start IN-” (pin #9) must be connected to an external GND (0V)**

## SPARE PARTS LIST

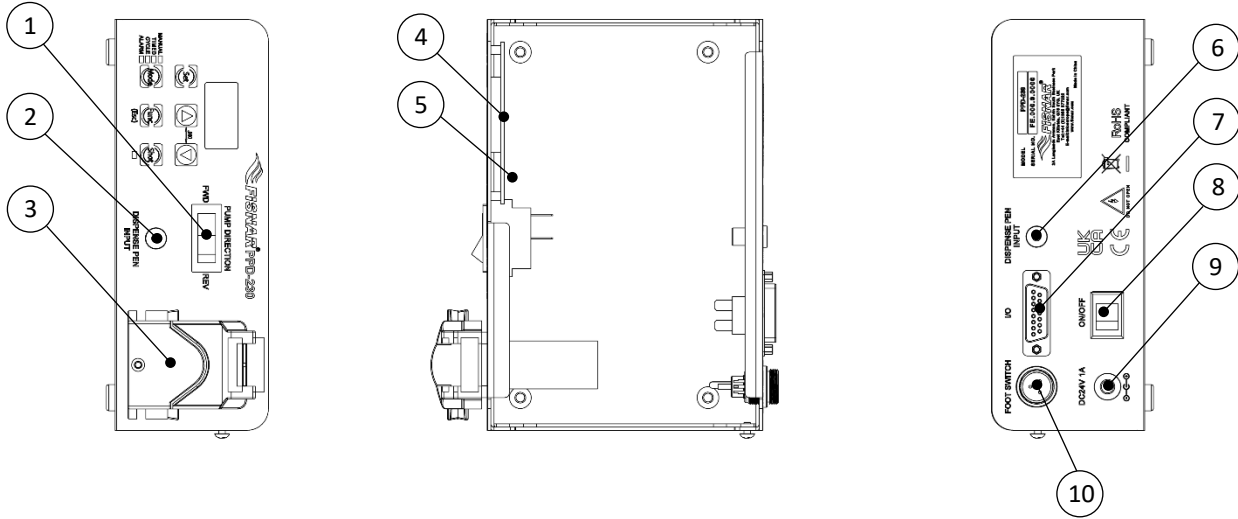

Ref.	Item Number	Description
1	5602020	Pump Direction Switch Assembly
2	5602021	Dispense Pen Input Connector Assembly
3	5602022	Pump Head & Motor Assembly
4	5601958-PPD230	Timer Board
5	5602023	Dispense Pen & Foot Switch Y-Connector Assembly
6	5602021	Dispense Pen Input Connector Assembly
7	5601961	I/O Connector Assembly
8	5601908	On/Off Switch Assembly
9	5601909	Power Input Connector Assembly
10	5601910	Foot Switch Connector Assembly

## Technical Drawing

### PPD-230 Peristaltic Pump Dispenser

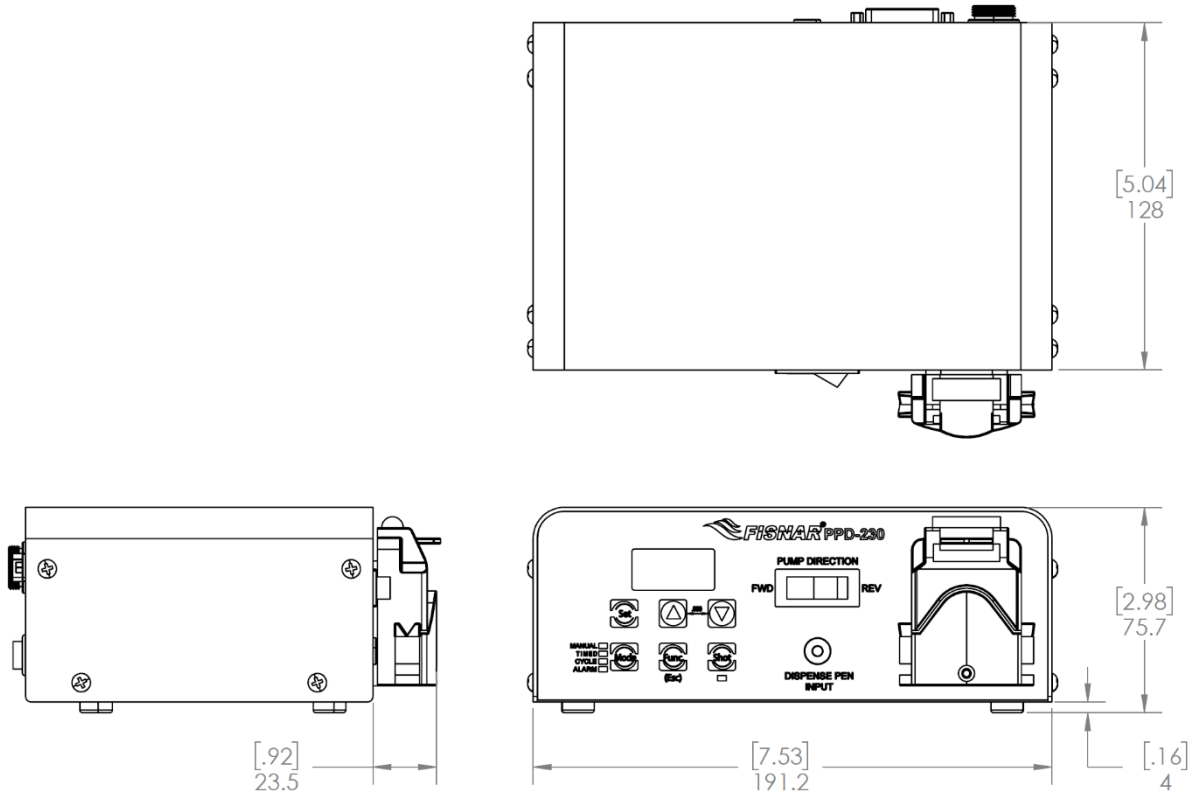

### 5602009 – Dispense Pen Assembly

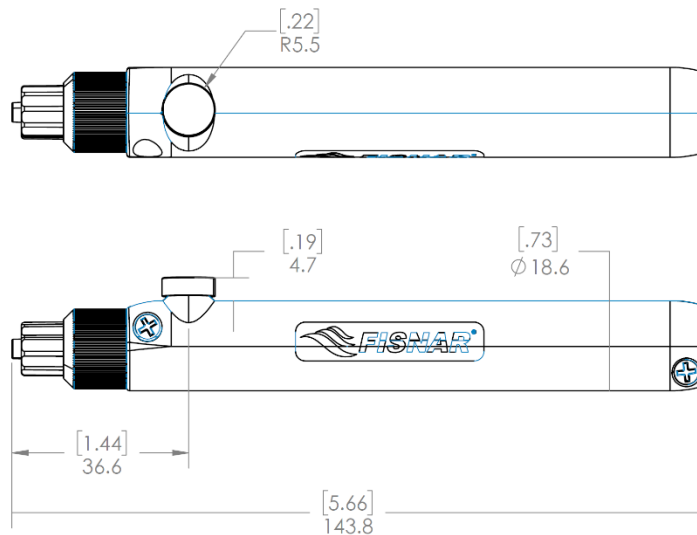

## Technical Drawing

### 5602016 - Dispense Pen Holder & Bottle Stand

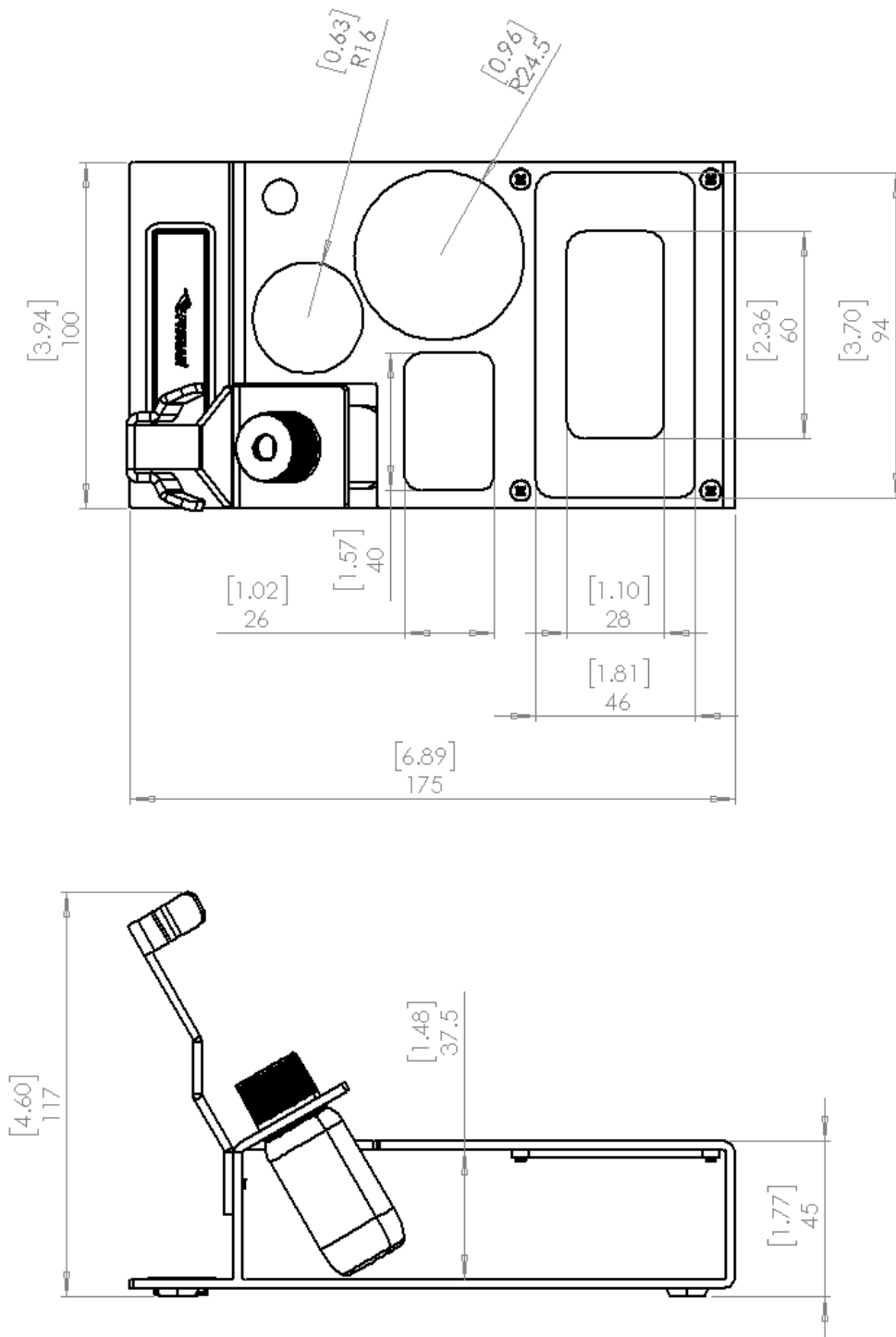

## APPENDIX 1

### Tubing Installation – Pen Body

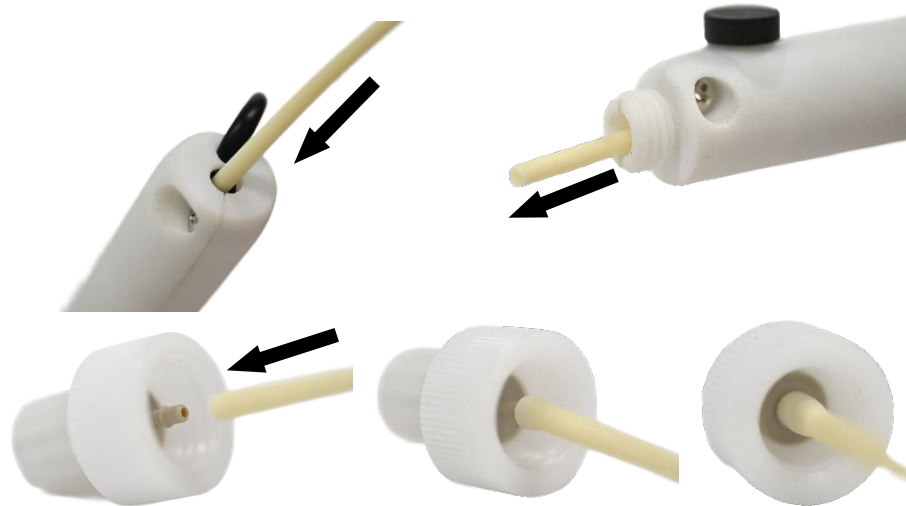

1. Select the preferred tubing from the different sizes / types available, for the dispense application and cut a suitable length as desired. (We recommend a minimum tubing length of 3ft is used.)

2. Insert one end of the tubing into the top hole of the pen body. Continue to feed the tubing through the pen body until it exits from the hole at the other end.

3. Select the appropriate sized dispense nozzle for the tubing being used, and the push the end of tubing that exited the pen body onto the hose barb of the dispense nozzle.

Dispense Nozzle	Innovasil™ Tubing	Innovaprene™ Tubing
 #5602010	#5602012	#5602013
 #5602011	#5602014	#5602015

**Note:-** Ensure the tubing is pushed fully over the hose barb so that the end of the tubing is in contact with the inner surface face of the dispense nozzle.

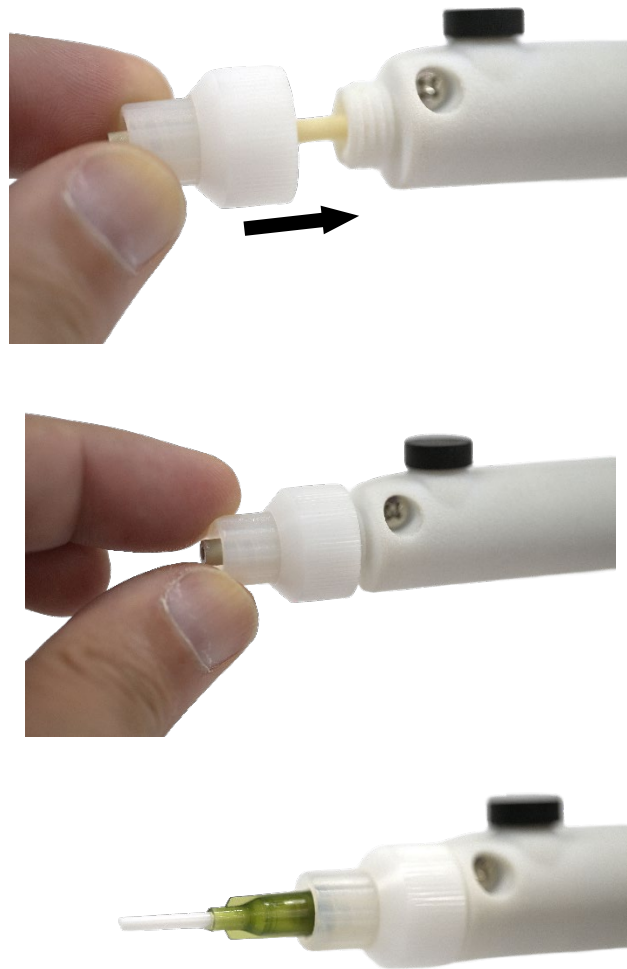

4.	Present the dispense nozzle & tube assembly up to the face of the thread on the dispense pen body.
5.	Rotate the dispense nozzle clockwise onto the thread of the dispense pen body by hand, until it is fully tightened in place.
6.	Install the desired and compatible luer lock dispense tip for the application and fluid being used onto the dispense nozzle

## APPENDIX 2

### Tubing Installation – Pump Head



1. Move the tab on the top of the pump head assembly upwards to open it.
2. Insert the tubing into either side of the pump head ensuring that the tubing is aligned with the molded v-grooves on each side of the upper pump head housing. Also make sure that the tubing is positioned over the center of the rollers within the pump head.
3. Move the tab on the top of the pump head assembly downwards to close it.  
Check again to make sure that the tubing is positioned between the molded v-grooves in both the upper and lower parts of the pump head housing.

## APPENDIX 3

### Tubing Installation – Fluid Reservoir



If the original source bottle is not being used as the fluid reservoir, fill the provided bottle (#EARB424 / #EARB424-BK) with the fluid to be dispensed.

1.

4oz Round Bottle - Natural (#EARB424)  
Use for fluids that do not react / cure in UV or visible light.

4oz Round Bottle - Black (#EARB424-BK)  
Use for fluids that react / cure in UV or visible light.

2.

Screw the snap top cap (#5602017) onto the upper thread of the bottle in a clockwise direction until it is fully tightened in place.

3.

Open the lid of the snap top cap (#5602017) and insert the tubing into hole on the top of the cap.

4.

Continue to feed the tubing into the bottle until it has fully reached the bottom of the bottle.

## NOTES

A large, empty rectangular box with a thin black border, intended for handwritten notes.

## LIMITED WARRANTY

Manufacturer warrants this product to the original purchaser for a period of one (1) year from the date of purchase to be free from defects in material and workmanship, but not against damages caused by misuse, negligence, accident, faulty installation, abrasion, corrosion or by not operating in accordance with factory recommendations and instructions. Manufacturer will repair or replace (at factory's option), free of charge, any component of the equipment thus found to be defective, upon prepaid return of the equipment to the factory during the warranty period of the equipment. In no event shall any liability or obligation of Manufacturer arising from this warranty exceed the purchase price of the equipment. The manufacturer's written liability, as stated herein, cannot be altered or enlarged except by a written statement signed by an officer of the company. In no event shall manufacturer be liable for consequential or incidental damages. A return authorization is required prior to shipping a defective machine to the factory.

Manufacturer reserves the right to make engineering or product modifications without notice.



[info@fisnar.com](mailto:info@fisnar.com)

[www.fisnar.com](http://www.fisnar.com)